



Linee automatiche  
di frittura e bollitura  
Automatic lines for  
frying and boiling production

## **AUTOMATIC DOSER WITH ONE OR TWO HEAD**



### **FEATURES:**

- Doser for pancakes and donuts that directly discharges on the fryer;
- Various shapes and dimensions of extrusion, depending on mold installed;
- Amount of variable dose;
- Adjustable dosing height;
- Continuous dosing over the entire width of the fryer;
- Adjustment of the lateral displacement speed to determine the distance between one dose and another;
- Quick return without dosing;
- Variable pause time after return;
- Possibility to adjust the lateral movement;
- Structure mounted on wheels, two fixed and two swivel with brake;
- Large compartment with closing door;
- Removable parts for possible remote maintenance;
- Easy cleaning.





Linee automatiche  
di frittura e bollitura  
Automatic lines for  
frying and boiling production

### TECHNICAL FEATURES:

- Overall dimensions cm 61x82x160;
- Hopper capacity with one head:≈ 10 Liters;
- Hopper capacity with two head:≈ 20 Liters;
- Control panel on the machine;
- Large compartment with closing door, to store items;
- Removable parts for cleaning;
- Structure and parts constructed integrally with materials suitable for contact with food;
- Maximum electric power used 250W;
- CE marking.

### TYPES OF STAMPS:



### DIMENSIONS:

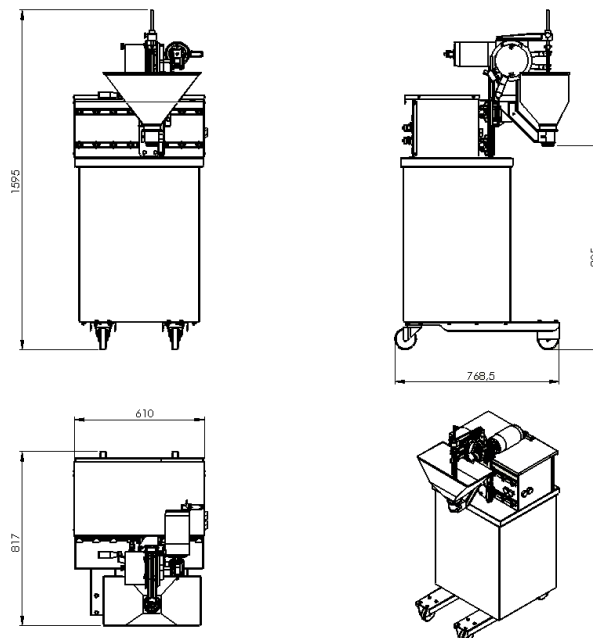

### Indicative hourly production:

The hourly production varies depending on the type of extrusion used and the number of extruders per head, for precise indications about the hourly production we invite you to make a specific request

AFRYER LTD Via Senatore Fabbri, 62 (Z.I. Lovadina) - 31027 Spresiano (TV) - Tel. +39 3519650377 Web site: <http://www.afryer.eu/>  
E-mail: [info@afryer.eu](mailto:info@afryer.eu) - P.IVA 05067780261 - C.F. 94165770267 - R.E.A. TV-426014

